

CAD FILE:

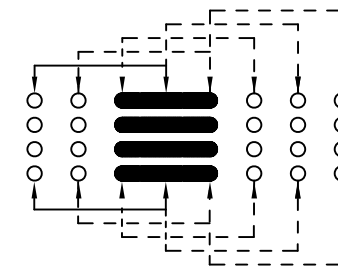

SCHMATIC (SHORTING)

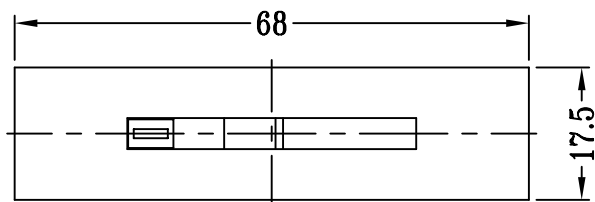
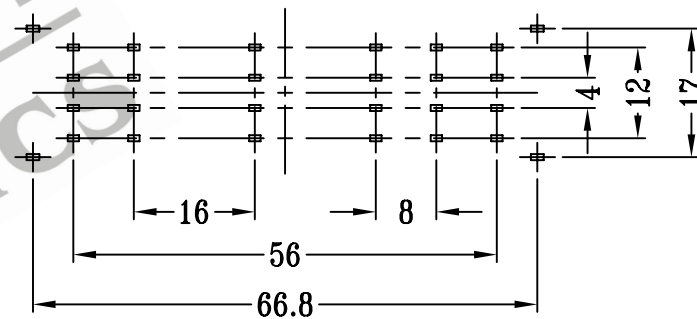
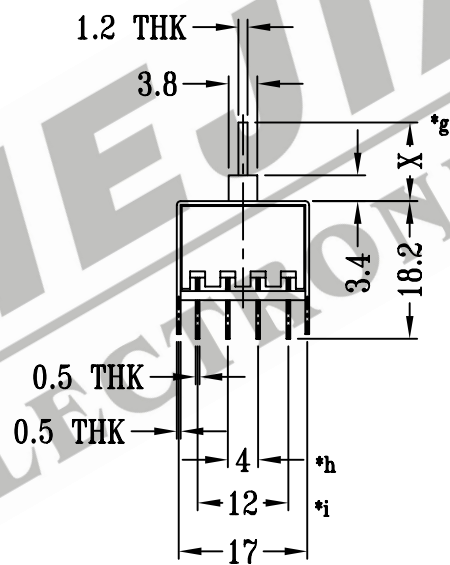
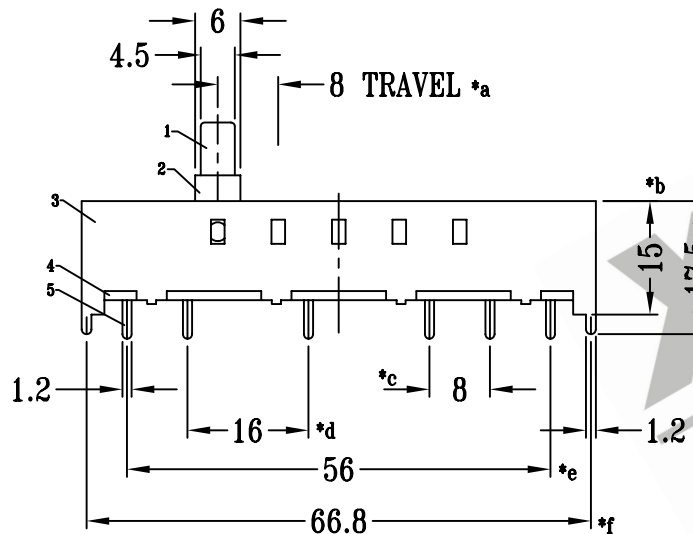

P.C.B LAYOUT

注:带"*"表示关键尺寸(9个)

8	CONTACT	COPPER STRIP	4	Ag PLATED	TOLERANCE UNLESS SPECIFIED	SHENZHEN XIEJIA ELECTRONICS CO.,LTD.				
7	SPRING	STEEL WIRE	9	TEMPER						
6	STEEL BALL	STEEL	2	NATURAL	WITHIN: 1.5±0.1mm	ISSUE	DATE	DESCRIPTIONS		APPD.
5	TERMINAL	BRASS STRIP	24	Ag PLATED OVER Ni PLATED	OVER : 1.5±0.2mm					
4	TERMINAL BASE	PHENOLIC RESIN	1	BLACK	TITLE : VERTICAL SLIDE SWITCH		UNIT : MM	DRWG NO.: XJ-DR-SS45P01-00		
3	FRAME	STEEL STRIP	1	Ni PLATED	MODEL: SS-45P01		SCALE: 1:1	DWN.	ZHOUYU	2003-9-21
2	KNOB	POM	1	BLACK	ALL MATERIALS MUST BE COMPLIANT TO ROHS			CHK'D	FANGYING	2003-9-21
1	STEEL KNOB	STEEL STRIP	1	Ni PLATED				APPD.	KANGXINAN	2003-9-21
NO.	PART NAME	MATERIAL	Q'TY	FINISHING						